

Expérimentation du temps négatif avec un circuit RC LP-NGD *Negative time experimentation with RC-network based low-pass NGD circuit*

B. Ravelo¹, N. B. Gurgel², S. Moussa^{3,4}, J. Rossignol⁵, Benoit Agnus⁶

¹NUIST, Nanjing 210044, Jiangsu, China, blaise.ravelo@yahoo.fr

²Applied EM & Microwave Lab., FUCG, Campina Grande 58429, Brazil, nathan.gurgel@ieee.org

³University of Antsirananana, 201 Antsirananana, Madagascar, moussainos@gmail.com

⁴LSE, LR11ES15, University of Tunis El Manar, ENIT, Tunis, Tunisia

⁵Université de Bourgogne, Dijon, France, jerome.rossignol@u-bourgogne.fr

⁶Scienteama, 4 Avenue de Cambridge, 14200 Hérouville Saint Clair, France, benoit.agnus@scienteama.fr

Mots-clés : Temps de Propagation de Groupe (TPG) négatif, avance temporelle, circuit RC, étude expérimentale.
Keywords: Negative group delay (NGD), Time-advance, Experimentation, RC-network.

Résumé

Cet article présente une étude expérimentale du temps négatif ($t < 0$) avec un circuit analogique RC. L'effet $t < 0$ est généré par la fonction électronique Temps de Propagation de Groupe (TPG) négatif ou NGD. Les principales caractéristiques de cette fonction inhabituelle, telles que l'avance temporelle et la fréquence de coupure du NGD en fonction des valeurs de résistance et de condensateur, sont présentées. Les résultats expérimentaux obtenus avec des signaux de forme d'onde arbitraire d'une durée de 23 ms confirment l'observation du $t < 0$ avec une avance temporelle d'environ -0,5 ms.

Abstract

This paper studies the negative time ($t < 0$) experimentation with RC-network electronic circuit. The $t < 0$ effect is generated from negative group delay (NGD) electronic function. The main characteristics of this uncommon function as time-advance and NGD cut-off frequency in function of resistor and capacitor elements are expressed. The experimental results with arbitrary waveform signals having 23 ms duration confirm the $t < 0$ observation with time-advance around -0.5 ms.

1 Introduction

Over the age, the history of science progresses naturally with emergency of successive new ideas upsetting the common and familiar ones. The experimental works constitute the decisive steps to bring the uncommon idea to the application area as a popular knowledge. Today, this historical process still happens when we have a close look about the sign of time status.

In 1980s, after theoretical intuitive postulate, the negative group delay (NGD) phenomenon was physically observed from negative group velocity media [1]. The existence and characterization of abnormal NGD function have attracted the attention of electronic engineering researchers since 1990s [2]. Thanks to the equivalence of transfer function (TF), NGD electronic topologies constituted by resistor, inductor, capacitor and operational amplifier were identified [2]. The particularity of NGD function is its possibility to propagate voltage signals with output detected in time-advance of its input [2-6]. Despite its counterintuitive behavior, it was emphasized that the NGD function does not contradict the causality [2]. However, so far, due to the plenty diversity of electronic topologies enabling to verify the possibility to demonstrate it, the meaning of NGD phenomenon remains an open question for non-specialist researchers.

For this reason, a fundamental basic NGD circuit theory inspired from the filter was initiated in the mid-2010s [3]. Even the topological structure can be exactly the same, the main difference between the NGD and filter circuit theory is the main function to be characterized. The filter circuits are essentially specified from the TF magnitude frequency response. However, the NGD circuits are elaborated from the group delay (GD) response. There may have confusion for non-specialists because the same electronic circuit topology can behave as both filter and NGD function.

It was pointed out from the developed fundamental theory that all NGD circuits can be innovatively identified as either low-pass (LP) or high-pass (HP) or bandpass (BP) or stopband (SB) or all-pass (AP) type topologies [4]. The present research work proposes a close look on the experimentation of LP type NGD function [4-6]. The LP-NGD topology under study is constituted by an RC-network [5-6]. We would like to popularize the possibility to analyze, characterize, study and experiment this LP type NGD topology. To do this, an experimental demonstration of negative time ($t < 0$) effect using LP-NGD circuit constitutes the main focus of the present work.

The paper is mainly organized in three main sections:

- Section 2 describes the theory of LP-NGD circuit constituted by RC-network,
- Section 3 examines the experimental work from the proof-of-concept and prototype dedicated to the $t < 0$ metrology,
- And Section 4 is the final conclusion.

2 Theory on the considered LP-NGD circuit composed of RC-network

This section addresses the theoretical analysis of the LP-NGD circuit constituted by an RC-network. The theory is established from the TF exploration. The main specifications of LP-NGD function are defined. Then, the design method of LP-NGD circuit is established in order to calculate the constituting component parameters in function of the desired to achieve $t < 0$ value.

2.1 Time-domain signature of LP-NGD function

The theory of electrical and electronic circuits exhibiting $t < 0$ behavior is elaborated under the same approach as the classical one. Based on the circuit and system theory, the linear time-invariant (LTI) TF approach represents the most pragmatic strategy to build an electronic engineering analytical investigation. We proceed under the same tradition for the present research work. Doing this, let represent the LP-NGD function as a two-port black box interacting with a time-dependent input signal $x(t)$ to generate the corresponding output $y(t)$ as illustrated in Fig. 1(a). The analytical expression of $t < 0$ concept studied in this work can be understood from the input and output signal transient relationship:

$$y(t) \approx x(t + t_a) \quad (1)$$

by taking $t_a < 0$ as time-advance parameter which represents a delay with negative sign.

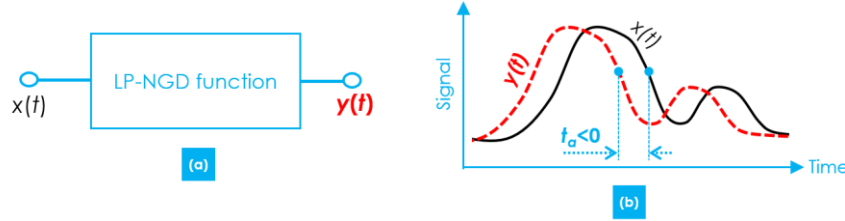

Figure 1: LP-NGD function (a) two-port black box and (b) time-domain signature diagram

To study this system in the frequency domain, the frequency variable is denoted by f . The LP-NGD TF $T(j2\pi f)$ can be expressed via the Fourier transform of input $X(j2\pi f)$ and output $Y(j2\pi f)$ which is traditionally expressed by the transmittance:

$$T(j2\pi f) = \frac{Y(j2\pi f)}{X(j2\pi f)} \quad (2)$$

The LP-NGD function basic definitions yielding from this TF are described in the next subsection.

2.2 Basic definitions for specifying the LP-NGD function

To materialize the LP-NGD function, we need a concrete electrical circuit in order to make us to be able to intelligibly experiment the $t < 0$ effect. Doing this, one considers the RC-network based LP-NGD topology attacked by input $x(t)$ and generating output $y(t)$ represented in Fig. 2. The LTI topology is constituted by $R_n // C_n$ and R -shunt passive network associated in upstream to an active cell with gain G . The LP-NGD analysis of this circuit consists in calculating the frequency responses following the circuit and system theory traditional approach.

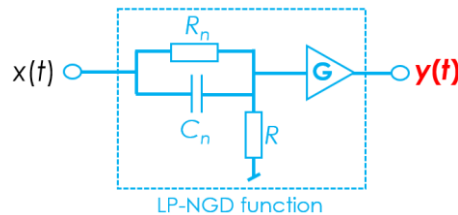

Figure 2: LP-NGD RC-network topology

Subsequently, the main parameters of the LP-NGD frequency domain study are the magnitude and phase classically expressed as:

$$T(f) = |T(2j\pi f)| = \sqrt{\text{real}[T(2j\pi f)]^2 + \text{imaginary}[T(2j\pi f)]^2} \quad (3)$$

$$\varphi(f) = \arg[T(2j\pi f)] = \arctan \left\{ \frac{\text{imaginary}[T(2j\pi f)]}{\text{real}[T(2j\pi f)]} \right\} \quad (4)$$

It yields from the latter one the GD parameter defined by:

$$GD(f) = \frac{1}{2\pi} \times \frac{-\partial \varphi(f)}{\partial f} \quad (5)$$

To reach the time-advance expressed in equation (1), as depicted in Fig. 3(a), we should have magnitude approximately equal to unity:

$$T(f \approx 0) \approx 1 \quad (6)$$

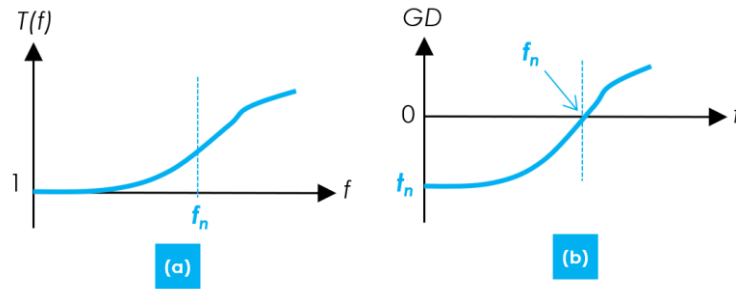

Figure 3: LP-NGD (a) magnitude and (b) GD frequency responses

It is more importantly to keep in mind that the LP-NGD function specifications are defined by:

- The GD value t_n at very low frequencies ($f \approx 0$) which must be negative:

$$t_n = GD(f \approx 0) < 0 \quad (7)$$

- And the NGD value f_n which is the root of equation:

$$GD(f = f_n) = 0 \quad (8)$$

Meanwhile, the LP-NGD function can be also analytically represented by the GD is spectrally negative:

$$\begin{cases} GD(f < f_n) < 0 \\ GD(f > f_n) > 0 \end{cases} \quad (9)$$

The exploitation of these two last equations permits to construct the LP-NGD theory of the topology introduced in Fig. 2.

2.3 LP-NGD analysis of the considered RC-network based topology

After the voltage TF exploration of the electrical circuit depicted in Fig. 2, one can mathematically demonstrate that the GD at very low frequency given in equation (7) is written as:

$$t_n = \frac{-R_n^2 C_n}{R + R_n} \quad (10)$$

We can remark that the GD t_n is always negative independently to the circuit resistor and capacitor values. Furthermore, the NGD cut-off frequency given in equation (8) becomes:

$$f_n = \frac{\sqrt{R + R_n}}{2\pi R_n C_n \sqrt{R}} \quad (11)$$

To operate with unity gain expressed in equation (6) at very low frequency, the LP-NGD active circuit must integrate an amplifier with static gain:

$$G = 1 + \frac{R_n}{R} \quad (12)$$

Of course, the gain must be more than unity $G > 1$ for an amplifier. These three last equations serve to establish the LP-NGD design equation elaborated in the next subsection.

2.4 Design equations of resistor and capacitor constituting the LP-NGD circuit

The concrete LP-NGD circuit diagram adopted in this work is represented in Fig. 4. It is terminated by a non-inverter amplifier with an operational amplifier associated to resistors R and R_n .

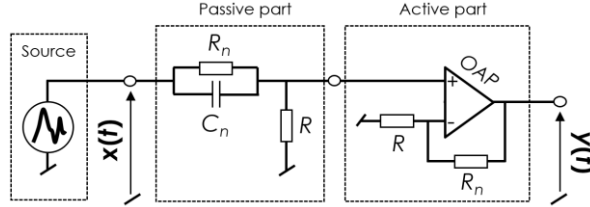

Figure 4: Adopted LP-NGD circuit to be designed and implemented

In function of the given gain $G > 1$ and time-advance $t_n = t_a < 0$, we can calculate the resistor and capacitor constituting the circuit proposed in Fig. 4 by inverting equations (9) and (10). To do this, we can, for example, fix resistance R_n as a given parameter. By inverting equation (10), we have the resistor design equation:

$$R = \frac{R_n}{G - 1} \quad (13)$$

Then, we have the capacitor design equation from equation (9):

$$C_n = \frac{-(R + R_n)t_a}{R_n^2} \quad (14)$$

This last term is always positive because we are dealing with $t_a < 0$. It is noteworthy that to experiment $t < 0$, the input signal spectrum bandwidth must belong to the base band spectrum $f < f_n$. This condition is also linked to the causality effect. It means that maximum bandwidth of input signal in function of the desired time-advance should be:

$$f_n = \frac{1 - G}{2\pi t_a \sqrt{G}} \quad (15)$$

The aim of the next section is to prove the feasibility of the established $t < 0$ circuit theory.

3 Negative time simulated and measurement results with LP-NGD prototype

This section focuses on the feasibility study of the LP-NGD function by experimentation of $t < 0$ effect with a circuit prototype.

3.1 Description of the demonstrator

The LP-NGD circuit proof-of-concept considered in this work is targeted to operate with t_a and amplifier gain G . After optimization and choice of nominal values, we utilized the components R , R_n and C_n having $\pm 5\%$ tolerances. Therefore, the LP-NGD cut-off frequency expressed in equation (14) is equal to f_n . All these parameters are indicated in Table 1.

Objective	Nature	Name	Value
Targeted specifications	Time-advance	t_a	-0.5 ms
	Amplifier gain	G	14 dB
LP-NGD circuit parameters	Resistor	R_n	2 k Ω
		R	500 Ω
	Capacitor	C_n	330 nF
NGD cut-off frequency	Frequency	f_n	569 Hz

Table 1: Specifications of the LP-NGD circuit proof-of-concept

The proof-of-concept of LP-NGD active prototype was designed in the SPICE environment of MULTISIM® as proposed in Fig. 5(a).

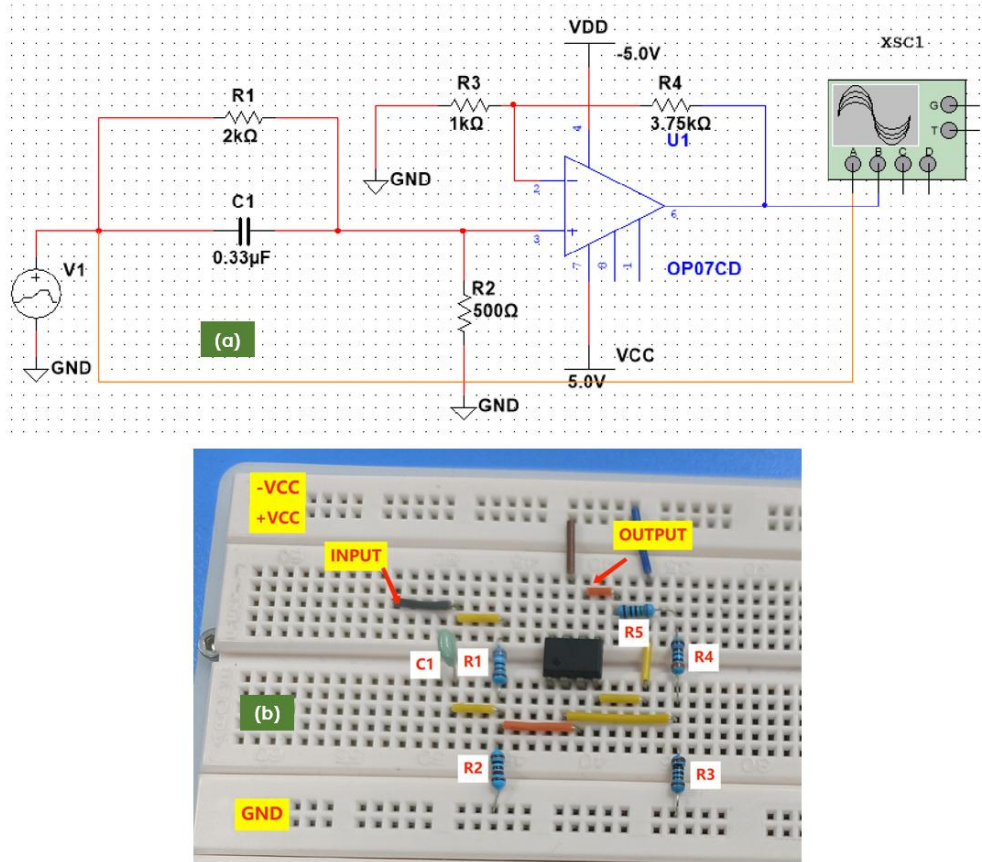

Figure 5: (a) MULTISIM® schematic and (b) tested prototype photo of LP-NGD circuit

In addition, the circuit prototype fed by DC power supply $V_{CC}=5$ VDC and $V_{DD}=-V_{CC}$ is implemented on a breadboard as seen in Fig. 5(b).

3.2 $t<0$ experimental setup

The present $t<0$ metrology was realized by simultaneous visualization of signals representing the input x and output y of LP-NGD circuit prototype. The performed experimentation was performed with the synoptic diagram illustrated in Fig. 6(a). As photographed in Fig. 6(b), the test is based on the input x provided from the arbitrary waveform signal generator with the visualization of the input and output signals by a digital oscilloscope. During the test, the LP-NGD active circuit prototype was fed by ± 5 V_{DC} power supply. The references of the test equipment are indicated in Table 2.

Instrument	Reference	Specifications
Digital oscilloscope	NDS102	<ul style="list-style-type: none"> - Precision: 12 bits - Bandwidth: 100-MHz - Sampling rate: 1 GSa/s
Signal generator	Siglent® SDG1062X	<ul style="list-style-type: none"> - Bandwidth: 60-MHz - Sampling rate: 150 MSa/s

Table 2: Test instrument specifications

The results of the carried-out experiment of LP-NGD prototype validating the counterintuitive effect $t<0$ are discussed in the next subsection.

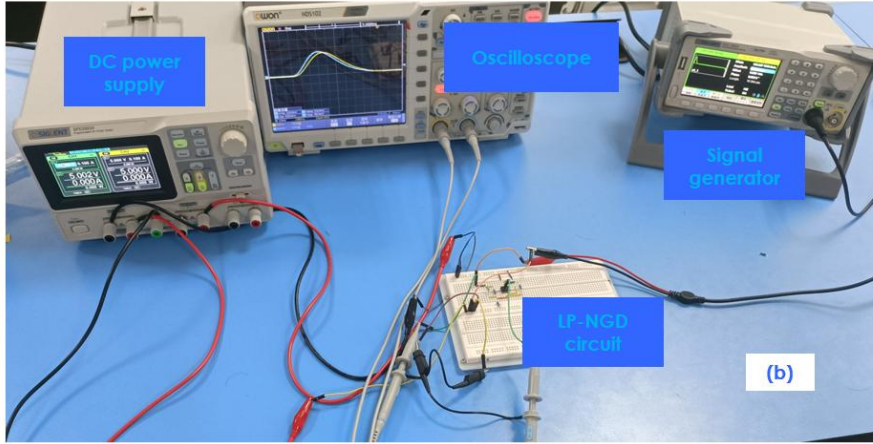
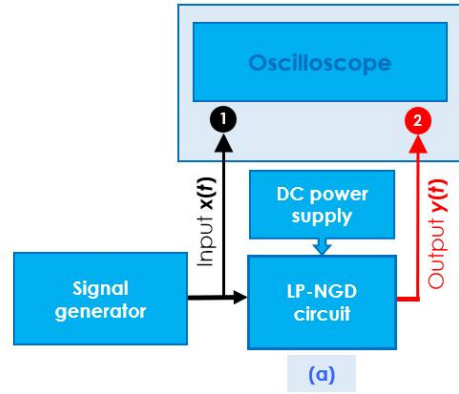

Figure 6: (a) Illustrative diagram and (b) photo of negative time testing with LP-NGD circuit

3.2 Discussion on the simulated and experimental results in the time-domain

The comparisons between time-domain results from the MULTISIM® simulation shown in Fig. 6(a) and measurement test photographed in Fig. 6(b) are plotted in Figs. 7.

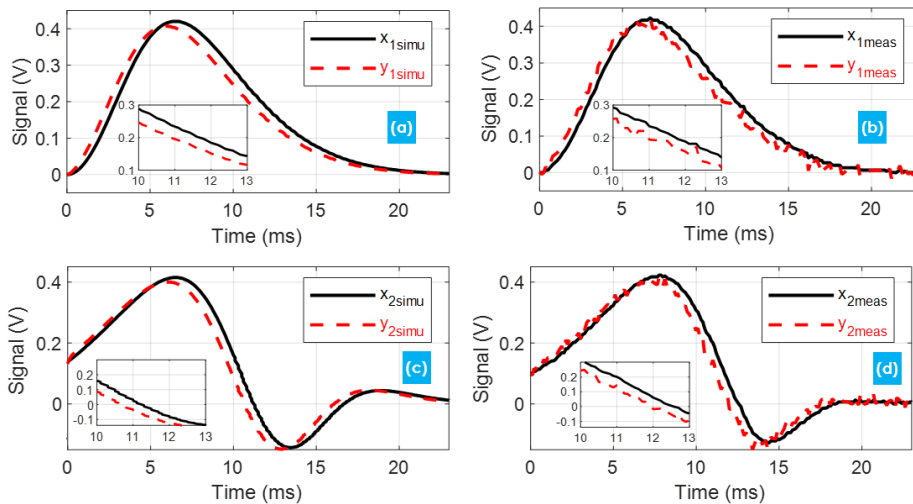

Figure 7: Responses of (a) simulated and (b) measured signal x_1 , and (c) simulated and (d) measured signal x_2

The experimentation was done by controlling the arbitrary wave form signal generator with CSV-format files containing the date of two-different input signals x_1 (bi-exponential waveform plotted in Fig. 7(a) and in Fig. 7(b)) and x_2 (arbitrary waveform plotted in Fig. 7(c) and in Fig. 7(d)). The time-domain experimental results were performed with input signals x plotted in black solid curves having 23 ms duration. The output signals y in apparent advance of x without violating the causality are plotted in red dashed curves. We can observe from Figs. 7 that the simulated and measured results are in good correlation. As expected, the output signals plotted in red dashed curves

present raising and falling edges in time-advance corresponding to ($t < 0$) effect. The transient outputs approximately expressed by:

$$\begin{cases} y_1(t) \approx x_1(t + t_{a1}) \\ y_2(t) \approx x_2(t + t_{a2}) \end{cases} \quad (16)$$

with $t_{a1}=t_{a2} \approx -0.43$ ms are observed.

4 Conclusion

The $t < 0$ effect is innovatively studied with NGD circuit. The fundamental LP-NGD circuit theory enabling to explore the counterintuitive $t < 0$ effect is developed. The basic specifications of the LP-NGD function are defined. Then, a concrete LP-NGD topology is studied from the TF examination. The mathematical demonstration showing why the circuit emanates the $t < 0$ effect is established. The design equations of LP-NGD circuit resistor and capacitor in function of the desired value of time-advance and the amplifier gain are formulated.

A study of LP-NGD circuit experimentation is presented by using an RC-network based topology. The NGD test technique is described. The simulation and measurement results confirm the LP-NGD effect. The $t < 0$ effect of about -0.5 ms is observed.

The time-advance property related to LP-NGD function can be exploited in term of prediction for very interesting potential applications especially in sensor [7-12], industrial, robotic, environmental, biologic and health medical areas where mostly using slow signals. The innovative idea can be understood with equation (1). By supposing, for example, we have LP-NGD circuit with any time-advance as $t_a = -1$ minute, the output $y(t) = x(t - 1 \text{ minute})$ represents the information about input with 1 minute in advance. Nowadays, according to recent research work results, the LP-NGD function application idea was validated with:

- LP-NGD analog circuit prototypes for:
 - Reconstruction of sensor signal distorted by unwanted perturbations [7],
 - Anticipating actuator with arbitrary mechanical actioning [8],
 - And temporally advanced detection of physiological medical signals [9],
- And also LP-NGD digital circuit prototypes for:
 - Luminosity sensing prediction [10],
 - CO₂ gas concentration prediction in real-time [11],
 - And real-time prediction of greenhouse temperature with results shown in Figs. 8 [12].

Acknowledgements: The present research work is supported by Natural National Science Foundation of China (NSFC) Grant No. 62350610268.

References

- [1] B. Ségard and B. Macke, "Observation of Negative Velocity Pulse Propagation," Phys. Lett. A, Vol. 109, pp. 213-216, 1985.
- [2] M. W. Mitchell and R. Y. Chiao, "Causality and Negative Group-delays in a Simple Bandpass Amplifier," Am. J. Phys., Vol. 66, pp. 14-19, 1998.
- [3] B. Ravelo, "Similitude between the NGD function and filter gain behaviours," Int. J. Circ. Theor. Appl., Vol. 42 No. 10, pp. 1016-1032, 2014.
- [4] B. Ravelo, "First-order low-pass negative group delay passive topology," Electronics Letters, Vol. 52 No. 2, pp. 124-126, 2016.
- [5] S. Junwen, C. Junyan, H. E. Silochi, R. Wieser, R. Sanchez Galan, N. M. Murad and B. Ravelo, "Positive-to-negative tunable delay circuit designed with NGD RC network," Int. J. Circ. Theor. Appl., Vol. 52, No. 10, pp. 5010-5024, Oct. 2024.
- [6] J. Y. Cui, H. E. Silochi, R. Wieser, S. Junwen, H. Bilal, S. Ngohe and B. Ravelo, "Familiarity analysis and time-advance experimental study of LP-NGD RC-circuit intended to operate with Unity-normalized gain," COMPEL-The int. j. for computation and math. in electrical and electronic eng., Vol. 43 No. 5, pp. 1007-1022, 2024.
- [7] B. Ravelo, W. Rahajandraibe, Y. Gan, F. Wan, N. M. Murad and A. Douyère, "Reconstruction Technique of Distorted Sensor Signals with Low-Pass NGD Function," IEEE Access, Vol. 8, No. 1, Dec. 2020, pp. 92182-92195.

- [8] B. Ravelo, F. Wan and J. Ge, "Anticipating Actuator Arbitrary Action with a Low-Pass Negative Group Delay Function," *IEEE Transactions on Industrial Electronics*, Vol. 68, No. 1, Jan. 2021, pp. 694-702.
- [9] C. Hymel, R. A. Stubbers and M. E. Brandt, "Temporally Advanced Signal Detection: A Review of the Technology and Potential Applications," *IEEE CAS Magazine*, vol. 11, no. 3, pp. 10-25, 3rd Quarter 2011.
- [10] B. Ravelo, M. Guerin, L. Rajaoarisoa and W. Rahajandraibe, "Luminosity Sensing Application of Negative Group Delay Predictor," *IEEE Transactions on Industrial Electronics*, vol. 71, no. 8, pp. 9875-9885, Aug. 2024.
- [11] B. Ravelo, M. Guerin, and W. Rahajandraibe, "Negative Group Delay Predictor Application for CO₂ Gas Concentration Real-Time Forecasting," *IEEE Sensors Journal*, Vol. 24, No. 3, 2024, pp. 3874-3887.
- [12] B. Ravelo, M. Guerin, W. Rahajandraibe and L. Rajaoarisoa, "Low-Pass NGD Digital Circuit Application for Real-Time Greenhouse Temperature Prediction," *IEEE Transactions on Circuits and Systems II: Express Briefs*, Vol. 70, No. 9, Sept. 2023, pp. 3709-3713.